

## Ultra-low Distortion, Ultra-low Noise Operational Amplifier

### General Description

The LME49990 is part of the ultra-low distortion, low noise, high slew rate operational amplifier series optimized and fully specified for high performance, high fidelity applications. The LME49990 combines low voltage noise density ( $0.9\text{nV}/\sqrt{\text{Hz}}$ ) with vanishing low THD+N (0.00001%). The LME49990 has a high slew rate of  $\pm 22\text{V}/\mu\text{s}$  and an output current capability of  $\pm 27\text{mA}$ . It drives  $600\Omega$  loads to within 2V of either power supply voltage.

The LME49990's outstanding Gain (135dB), CMRR (137dB), PSRR (144dB), and  $V_{OS}$  ( $130\mu\text{V}$ ) give the amplifier excellent operational amplifier DC performance. The LME49990 has a wide supply range of  $\pm 5\text{V}$  to  $\pm 18\text{V}$ . The LME49990 is unity gain stable and is available in an 8-lead narrow body SOIC.

### Key Specifications

■ Input Noise Density ( $f = 1\text{kHz}$ )	$0.9\text{nV}/\sqrt{\text{Hz}}$ (typ) $1.3\text{nV}/\sqrt{\text{Hz}}$ (max)
■ THD+N ( $A_V = 1, V_{OUT} = 3V_{RMS}, f_{IN} = 1\text{kHz}$ $R_L = 600\Omega$ )	0.00001%
■ 1/f Corner Frequency	43Hz (typ)
■ Slew Rate	$\pm 22\text{V}/\mu\text{s}$ (max)
■ Gain Bandwidth ( $A_V = 10^4, R_L = 2\text{k}\Omega, f = 90\text{kHz}$ )	110MHz (typ)
■ PSRR	144dB (typ)
■ CMRR	137dB (typ)
■ Power Supply Voltage Range	$\pm 5\text{V}$ to $\pm 18\text{V}$

### Features

- Easily drives  $600\Omega$  load
- Output short circuit protection

### Applications

- Ultra high quality audio signal processing
- Active Filters
- Preamplifiers
- Spectrum analyzers
- Ultrasound preamplifiers
- Sigma-Delta ADC/DAC buffers

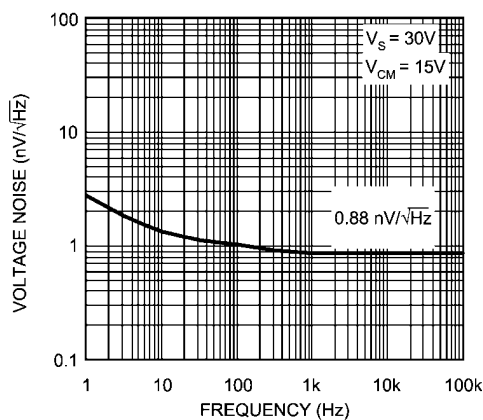

FIGURE 1. Voltage Noise Spectral Density 300597e6

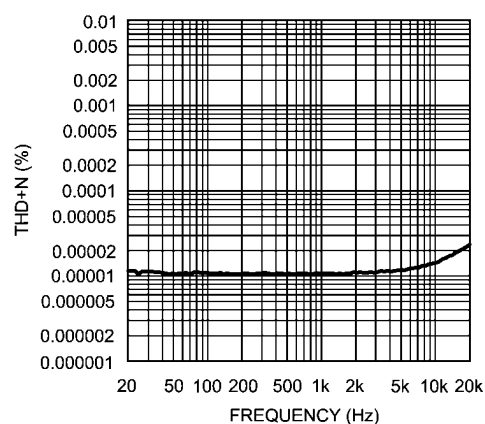
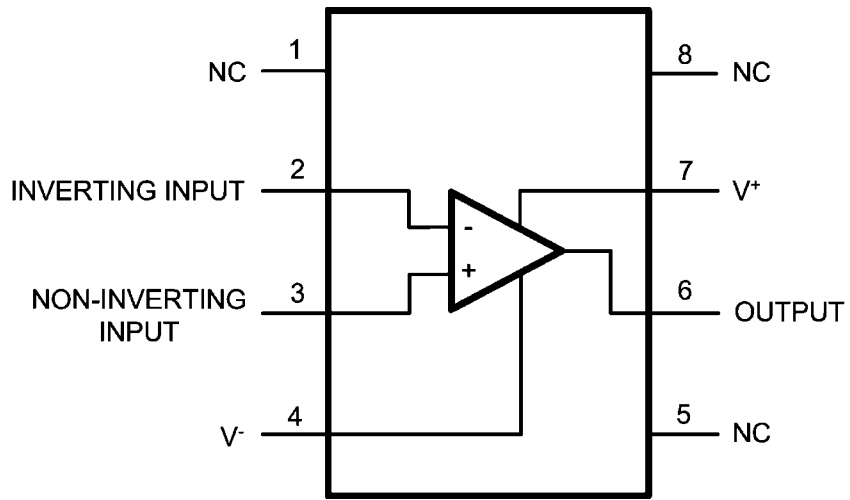

FIGURE 2. THD+N vs Frequency 300597d7

### Connection Diagram



30059702

Order Number LME49990MA  
See NS Package Number — M08A

### Ordering Information

Order Number	Package	Package DWG #	Transport Media	MSL Level
LME49990MA	8 Ld SOIC	M08A	95 units in reel	1
LME49990MAX	8 Ld SOIC	M08A	2500 units in tape and reel	1

**Absolute Maximum Ratings** (Note 1)

If Military/Aerospace specified devices are required, please contact the National Semiconductor Sales Office/Distributors for availability and specifications.

Power Supply Voltage ( $V_S = V^+ - V^-$ )	38V
Storage Temperature	-65°C to 150°C
Input Voltage	( $V^-$ ) - 0.3V to ( $V^+$ ) + 0.3V
Output Short Circuit (Note 3)	Continuous
Power Dissipation	Internally Limited
ESD Rating (Note 4)	2000V
ESD Rating (Note 5)	200V

ESD Rating (Note 8)	1000V
Junction Temperature	150°C
Thermal Resistance $\theta_{JA}$ (SO)	145°C/W
Soldering Information Infrared or Convection (20 sec)	260°C

**Operating Ratings** (Note 1)

Temperature Range $T_{MIN} \leq T_A \leq T_{MAX}$	-40°C $\leq$ $T_A$ $\leq$ 85°C
Supply Voltage Range	$\pm 5V \leq V_S \leq \pm 18V$

**Electrical Characteristics** (Note 2)

The following specifications apply for  $V_S = \pm 15V$ ,  $R_L = 2k\Omega$ ,  $f_{IN} = 1kHz$ , and  $T_A = 25^\circ C$ , unless otherwise specified.

Symbol	Parameter	Conditions	LME49990		Units (Limits)
			Typical	Limit	
			(Note 6)	(Note 7)	
<b>POWER SUPPLY</b>					
$V_{CC}$	Operating Supply Voltage			$\pm 5$ $\pm 18$	V (min) V (max)
$I_{CCQ}$	Quiescent Current	$V_{CM} = 0V$ , $V_O = 0V$ , $I_O = 0mA$ $V_{CC} = \pm 5V$ $V_{CC} = \pm 15V$ $V_{CC} = \pm 18V$	8 9 9	10 11 12	mA (max)
PSRR	Power Supply Rejection Ratio	$V_{CC} = \pm 5V$ to $\pm 18V$ $T_{MIN} - T_{MAX}$	144 137	119 116	dB (min) dB (min)
<b>DYNAMIC PERFORMANCE</b>					
THD+N	Total Harmonic Distortion + Noise	$A_V = 1$ , $V_O = 3V_{RMS}$ , $R_L = 1k\Omega$ $f = 1kHz$ $f = 20kHz$	0.00001 0.00003	0.00002	% (max) %
IMD	Intermodulation Distortion	$A_V = 1$ , $V_O = 3V_{RMS}$ Two-tone 60Hz & 7kHz 4:1	0.000017		%
GBWP	Gain Bandwidth Product	$A_V = 10^4$ , $R_L = 2k\Omega$ , $f = 90kHz$	110		MHz
FPBW	Full Power Bandwidth	$A_V = -1$ , $V_O = 20V_{PP}$ , $R_L = 1k\Omega$	291		kHz
SR	Slew Rate	$A_V = -1$ , $V_O = 20V_{PP}$ $R_L = 1k\Omega$	22	16.5	V/ $\mu s$ (min)
$t_s$	Settling time	$A_V = -1$ , $V_O = 10V_{PP}$ , $R_L = 1k\Omega$ 0.01%	590		ns
$A_{VOL}$	Open-Loop Gain	$V_O = \pm 10V$			
		$R_L = 2k\Omega$ $T_{MIN} - T_{MAX}$	135 124	120	dB (min) dB
		$R_L = 600\Omega$ $T_{MIN} - T_{MAX}$	130 122	120	dB (min) dB

Symbol	Parameter	Conditions	LME49990		Units (Limits)
			Typical	Limit	
			(Note 6)	(Note 7)	
<b>NOISE</b>					
$e_N$	Input Noise Voltage Density	$f = 10\text{Hz}$	1.4		$\text{nV}/\sqrt{\text{Hz}}$
		$f = 100\text{Hz}$	1.0		$\text{nV}/\sqrt{\text{Hz}}$
		$f = 1\text{kHz}$	0.88	1.3	$\text{nV}/\sqrt{\text{Hz}}$ (max)
		$f = 10\text{kHz}$	0.88		$\text{nV}/\sqrt{\text{Hz}}$
$V_{\text{NOISE}}$	RMS Voltage Noise	$\text{BW} = 0.1\text{Hz to } 10\text{Hz}$ (Note 4)	30		$\text{nV}_{\text{PP}}$
		$\text{BW} = 10\text{Hz to } 20\text{kHz}$	0.12	0.2	$\mu\text{V}$ (max)
		$\text{BW} = 10\text{Hz to } 1\text{MHz}$	1	1.2	$\mu\text{V}$ (max)
$i_N$	Input Current Noise Density	$f = 1\text{kHz}$	2.8		$\text{pA}/\sqrt{\text{Hz}}$
<b>INPUT CHARACTERISTICS</b>					
$V_{\text{OS}}$	Offset Voltage	$V_{\text{CC}} = \pm 18\text{V}, V_{\text{CM}} = 0\text{V}, V_{\text{O}} = 0\text{V}$	130	1000	$\mu\text{V}$ (max)
		$V_{\text{CC}} = \pm 18\text{V}, T_{\text{MIN}} - T_{\text{MAX}}$	300	2000	$\mu\text{V}$ (max)
$V_{\text{OS Drift}}$	Input Offset Voltage Drift vs Temperature ( $\Delta V_{\text{OS}}/\Delta\text{Temp}$ )	$V_{\text{CC}} = \pm 18\text{V}, T_{\text{MIN}} - T_{\text{MAX}}$	2		$\mu\text{V}/^\circ\text{C}$
$I_{\text{BIAS}}$	Input Bias Current	$V_{\text{CC}} = \pm 18\text{V}, V_{\text{CM}} = 0\text{V}, V_{\text{O}} = 0\text{V}$	30	500	$\text{nA}$ (max)
		$V_{\text{CC}} = \pm 18\text{V}, T_{\text{MIN}} - T_{\text{MAX}}$	150	1000	$\text{nA}$ (max)
$I_{\text{OS}}$	Input Offset Current	$V_{\text{CC}} = \pm 18\text{V}, V_{\text{CM}} = 0\text{V}, V_{\text{O}} = 0\text{V}$	35	400	$\text{nA}$ (max)
		$V_{\text{CC}} = \pm 18\text{V}, T_{\text{MIN}} - T_{\text{MAX}}$	95	1000	$\text{nA}$ (max)
$V_{\text{IN-CM}}$	Common-Mode Input Voltage Range		12	11	$\text{V}$ (min)
CMRR	Common-Mode Rejection	$-10\text{V} < V_{\text{CM}} < 10\text{V}$	137	118	$\text{dB}$ (min)
		$T_{\text{MIN}} - T_{\text{MAX}}$	132	110	$\text{dB}$ (min)
<b>OUTPUT CHARACTERISTICS</b>					
$V_{\text{OUT}}$	Output Voltage Swing	$V_{\text{CC}} = \pm 15\text{V}, R_{\text{L}} = 2\text{k}\Omega$	$\pm 13$	12.5	$\text{V}$ (min)
		$V_{\text{CC}} = \pm 15\text{V}, R_{\text{L}} = 600\Omega$	$\pm 13$	12	$\text{V}$ (min)
		$V_{\text{CC}} = \pm 18\text{V}, R_{\text{L}} = 600\Omega$	$\pm 16$	14.0	$\text{V}$ (min)
$I_{\text{SHIRT}}$	Output Short-Circuit Current	$V_{\text{CC}} = \pm 18\text{V}$	+75/-70	+55/-50	$\text{mA}$ (min)
$I_{\text{OUT}}$	Output Current	$V_{\text{CC}} = \pm 18\text{V}, R_{\text{L}} = 600\Omega$	26	24	$\text{mA}$ (min)

**Note 1:** "Absolute Maximum Ratings" indicate limits beyond which damage to the device may occur, including inoperability and degradation of device reliability and/or performance. Functional operation of the device and/or non-degradation at the *Absolute Maximum Ratings* or other conditions beyond those indicated in the *Recommended Operating Conditions* is not implied. The *Recommended Operating Conditions* indicate conditions at which the device is functional and the device should not be operated beyond such conditions. All voltages are measured with respect to the ground pin, unless otherwise specified.

**Note 2:** The *Electrical Characteristics* tables list guaranteed specifications under the listed *Recommended Operating Conditions* except as otherwise modified or specified by the *Electrical Characteristics Conditions* and/or Notes. Typical specifications are estimations only and are not guaranteed.

**Note 3:** Amplifier output connected to GND, any number of amplifiers within a package.

**Note 4:** Human body model, applicable std. JESD22-A114C.

**Note 5:** Machine model, applicable std. JESD22-A115-A.

**Note 6:** Typical values represent most likely parametric norms at  $T_A = +25^\circ\text{C}$ , and at the *Recommended Operation Conditions* at the time of product characterization and are not guaranteed.

**Note 7:** Datasheet min/max specification limits are guaranteed by test or statistical analysis.

**Note 8:** Charge device model, applicable std JESD22-C101-A.

# Typical Performance Characteristics

**THD+N vs Output Voltage**  
 $V_{CC} = -V_{EE} = 15V, R_L = 2k\Omega$

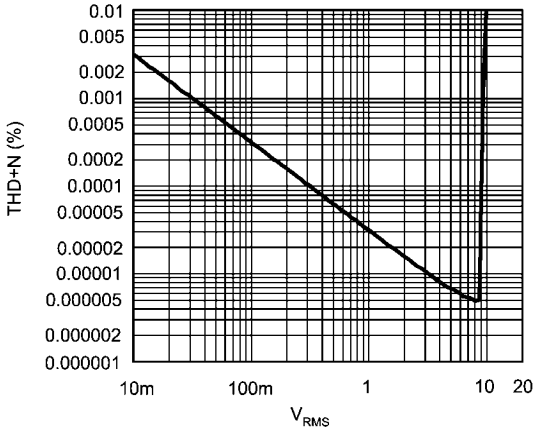

300597e9

**THD+N vs Output Voltage**  
 $V_{CC} = -V_{EE} = 18V, R_L = 2k\Omega$

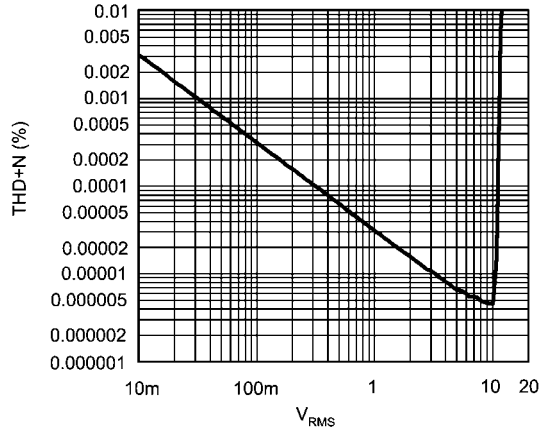

300597f1

**THD+N vs Output Voltage**  
 $V_{CC} = -V_{EE} = 5V, R_L = 2k\Omega$

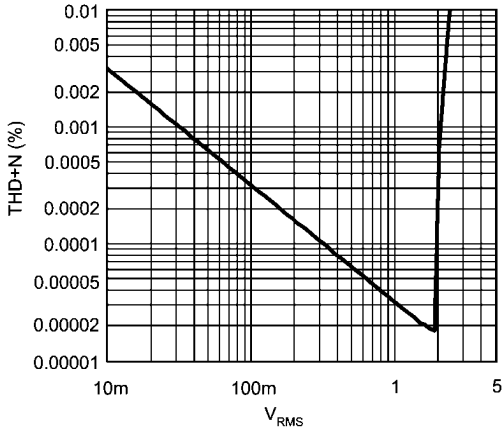

300597e7

**THD+N vs Output Voltage**  
 $V_{CC} = -V_{EE} = 15V, R_L = 600\Omega$

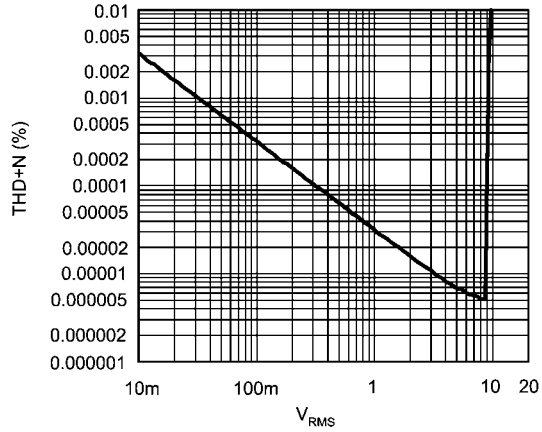

300597f0

**THD+N vs Output Voltage**  
 $V_{CC} = -V_{EE} = 18V, R_L = 600\Omega$

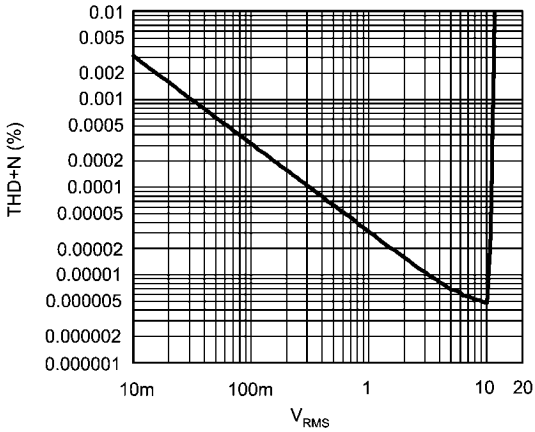

300597f2

**THD+N vs Output Voltage**  
 $V_{CC} = -V_{EE} = 5V, R_L = 600\Omega$

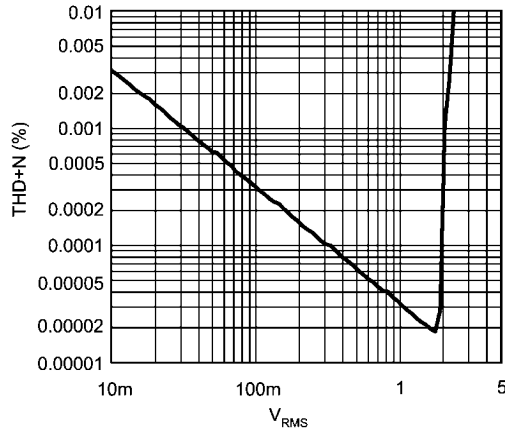

300597e8

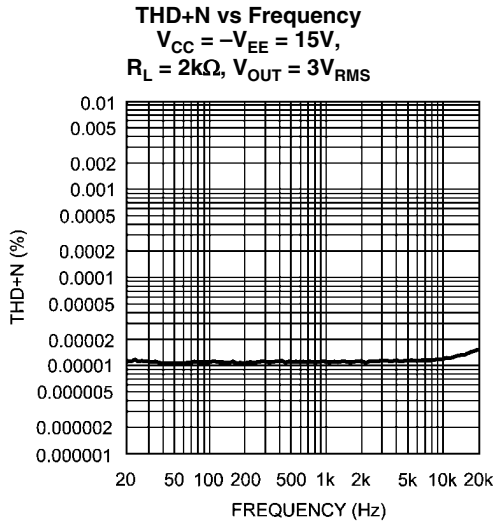

300597d6

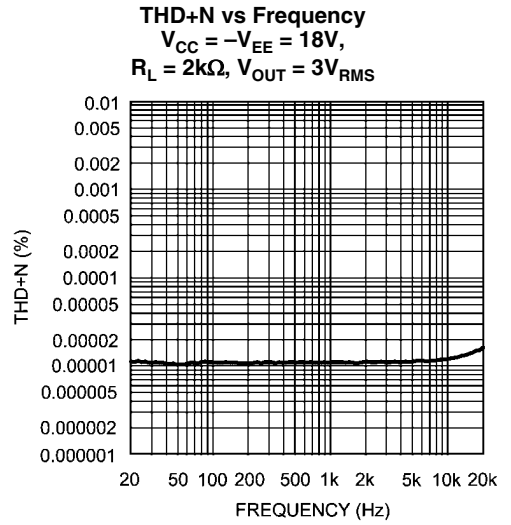

300597d8

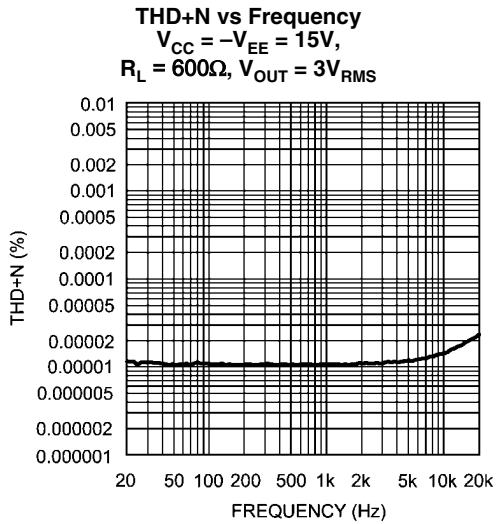

300597d7

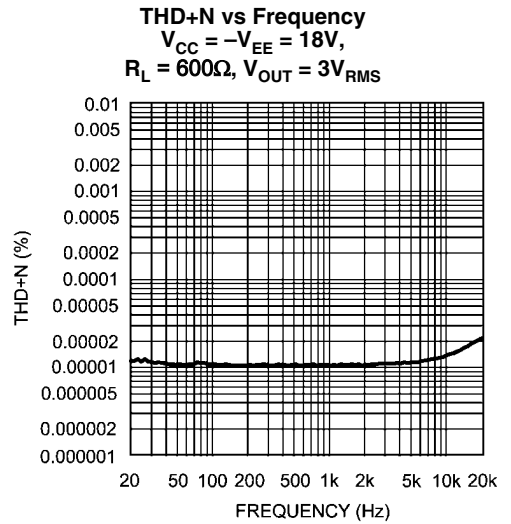

300597d9

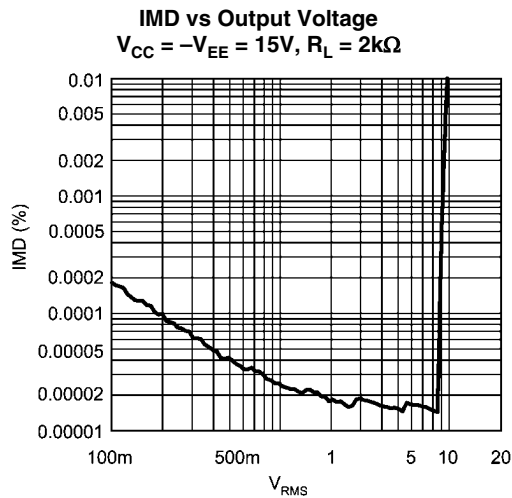

300597d1

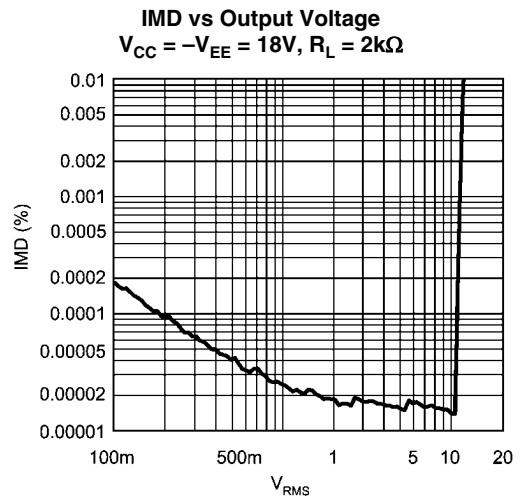

300597d3

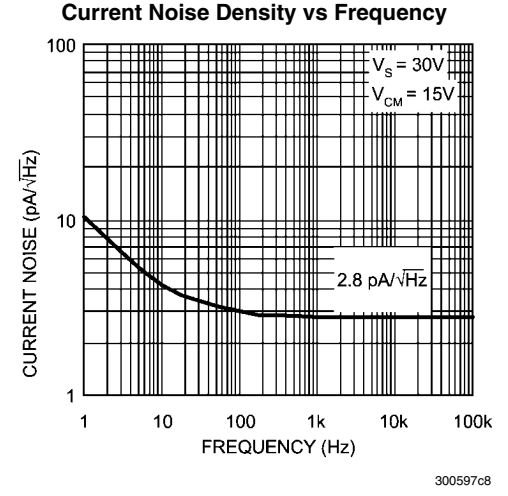
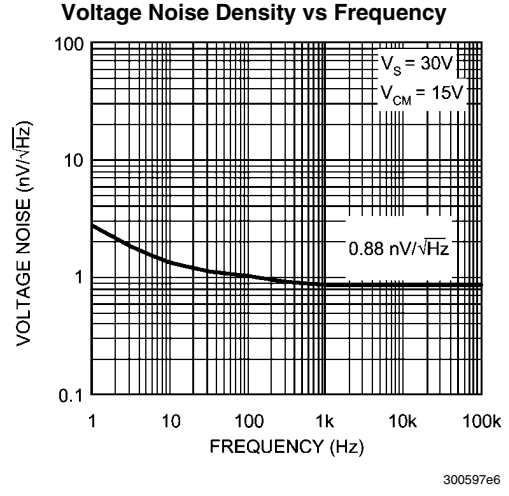
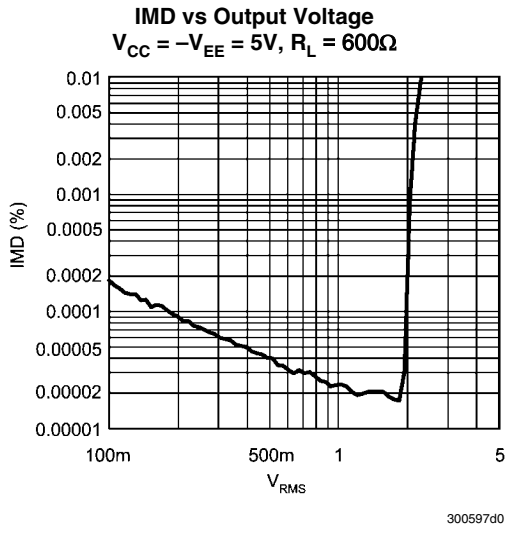
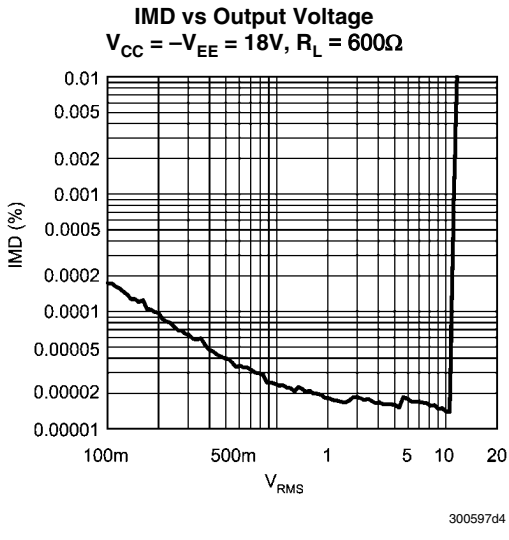
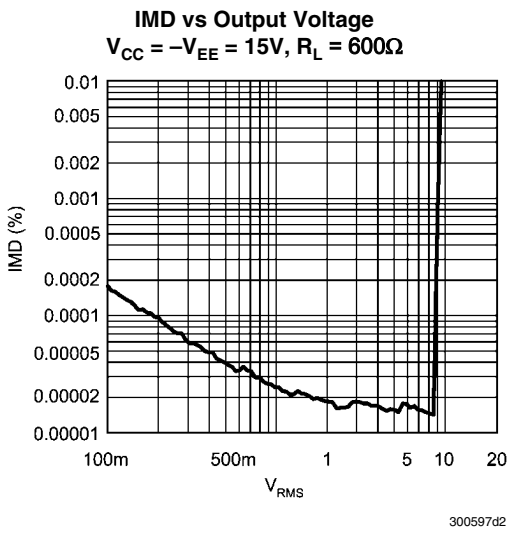
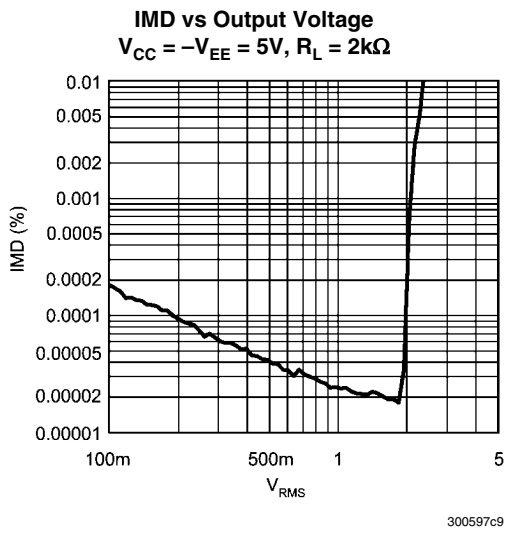

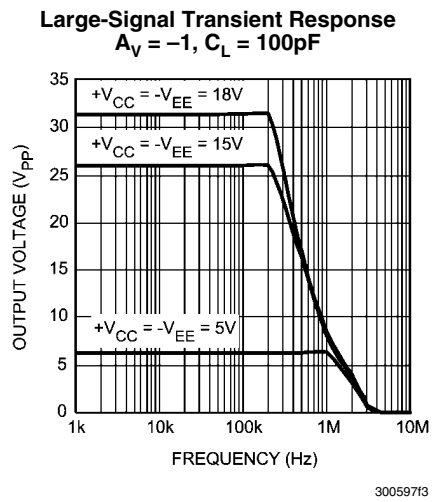
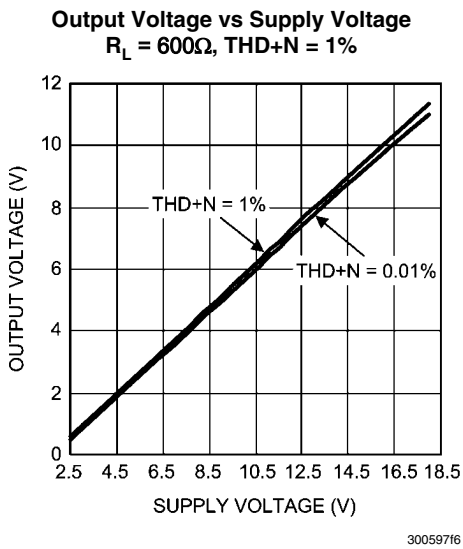
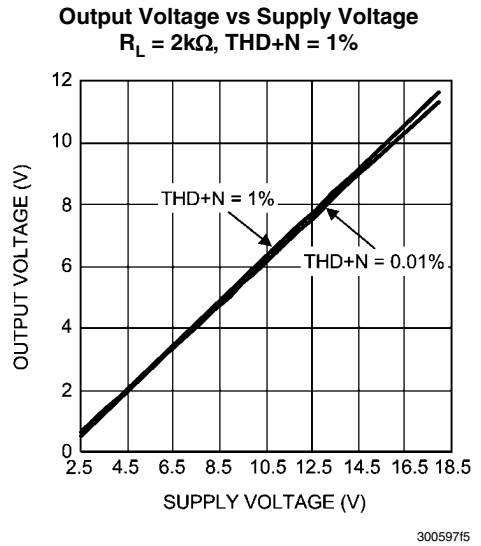
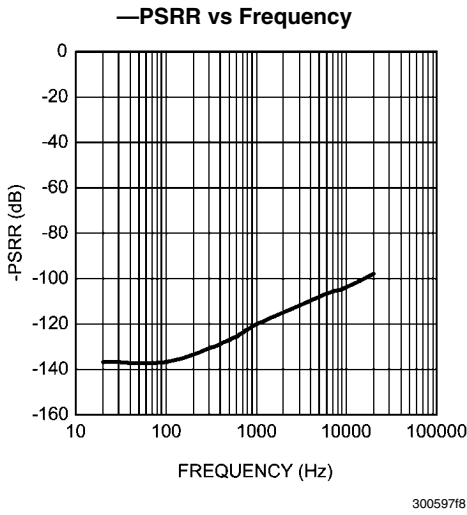
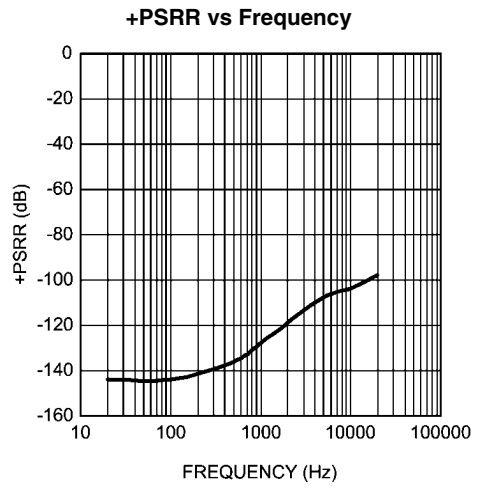
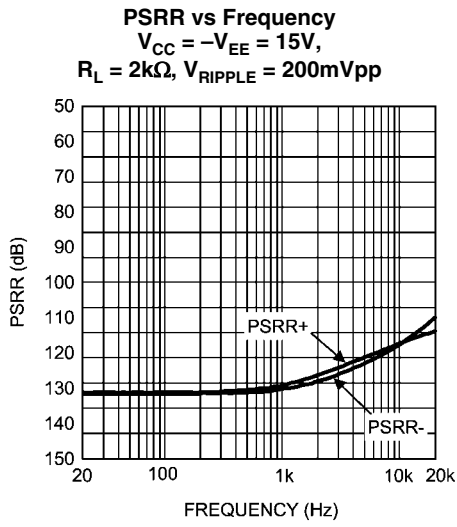



## Application Hints

### OUTPUT DRIVE AND STABILITY

The LME49990 is unity gain stable from both input (both stable when gain = -1 or gain = 1). It able to drive resistive load  $600\Omega$  with output circuit with a typical 27mA. Capacitive loads up to 100pF will cause little change in the phase characteristics of the amplifiers and are therefore allowable.

Capacitive loads greater than 100pF must be isolated from the output. The most straight forward way to do this is to put a resistor in series with the output. This resistor will also prevent excess power dissipation if the output is accidentally shorted.

The effective load impedance (including feedback resistance) should be kept above  $600\Omega$  for fast settling. Load capacitance should also be minimized if good settling time is to be optimized. Large feedback resistors will make the circuit more susceptible to stray capacitance, so in high-speed applications keep the feedback resistors in the  $1k\Omega$  to  $2k\Omega$  range whenever practical.

### OUTPUT COMPENSATION

In most of the audio applications, the device will be operated in a room temperature and compensation networks are not necessary. However, the consideration of output network as shown in Figure 3 may be taken into account for some of the high performance audio applications such as high speed data conversion or when operating in a relatively low junction temperature. The compensation network will also provide a small improvement in settling time for the response time demanding applications.

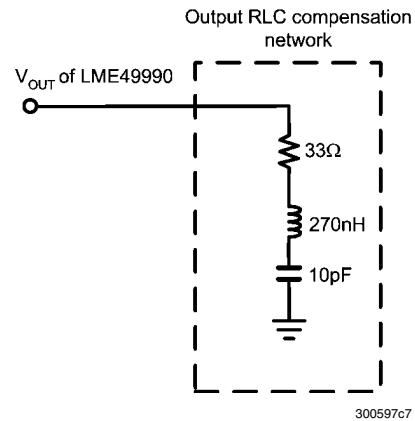

FIGURE 3. LME4990 Output Compensation Network

### SUPPLY BYPASSING

To achieve a low noise and high-speed audio performance, power supply bypassing is extremely important. Applying multiple bypass capacitors is highly recommended. From experiment results, a  $10\mu\text{F}$  tantalum,  $2.2\mu\text{F}$  ceramic, and a  $0.47\mu\text{F}$  ceramic work well. All bypass capacitors leads should be very short. The ground leads of capacitors should also be separated to reduce the inductance to ground. To obtain the best result, a large ground plane layout technique is recommended and it was applied in the LME49990 evaluation board.

## Typical Applications

Balanced Input Mic Amp

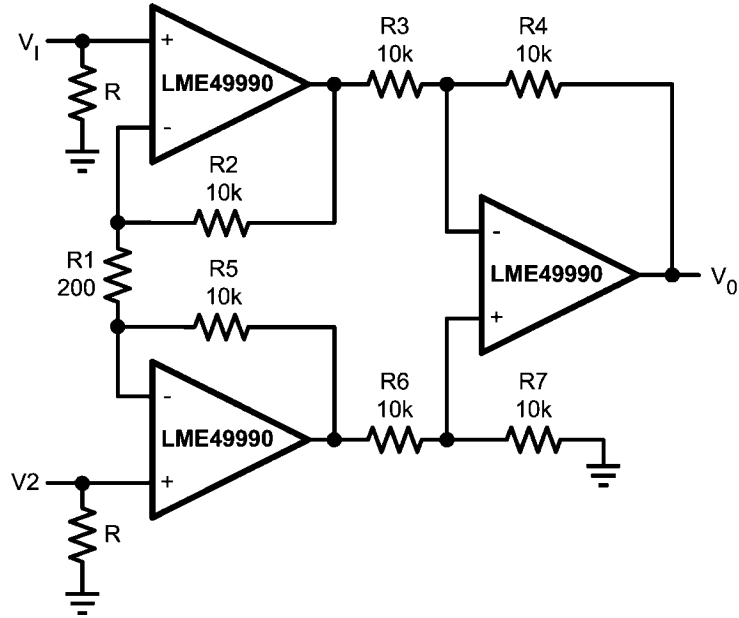

30059743

If  $R2 = R5, R3 = R6, R4 = R7$

$$V_0 = \left(1 + \frac{2R2}{R1}\right) \frac{R4}{R3} (V2 - V1)$$

Illustration is:

$$V_0 = 101(V2 - V1)$$

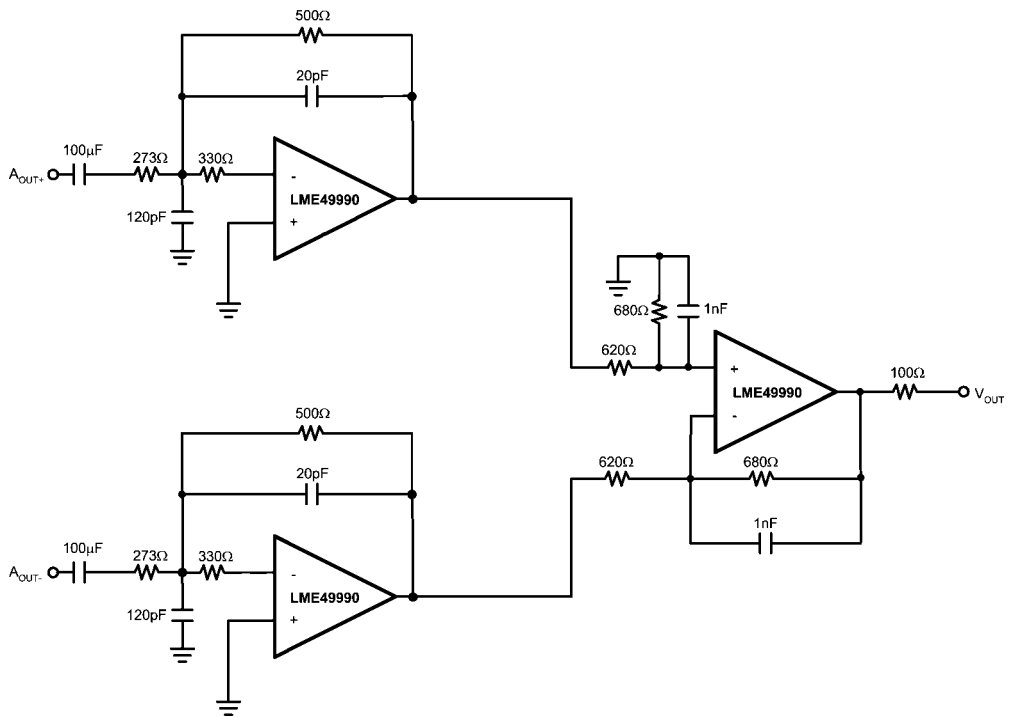

MFB 3rd Order PCM LPF

300597c6

## Application Information

### SETTLING TIME AND SLEW RATE MEASUREMENTS

The settling time of LME49990 may be verified using the test circuit in Figure 6. The LME49990 is connected for inverting operation, and the output voltage is summed with the input voltage step. When the LME49990's output voltage is equal to the input voltage, the voltage on the PROBE 1 will be zero. Any voltage appearing at this point will represent an error. And the settling time is equal to the time required for the error signal displayed on the oscilloscope to decay to less than one-half the necessary accuracy (See Settling Time – Output Swing photo). For a 10V input signal, settling time to 0.01% (1mV) will occur when the displayed error is less than 0.5mV. Since settling time is strongly dependent on slew rate, settling will be faster for smaller signal swings. The LME49990's inverting slew rate is faster than its non-inverting slew rate, so settling will be faster for inverting applications, as well.

It is important to note that the oscilloscope input amplifier may be overdriven during a settling time measurement, so the oscilloscope must be capable of recovering from overdrive very quickly. The signal generator used for this measurement must be able to drive  $50\Omega$  with a very clean  $\pm 10V_{pp}$  square wave.

The Slew Rate of LME49990 tells how fast it responds to a transient or a step input. It may be measured by the test circuit in Figure 7. The Slew Rate of LME49990 is specified in close-loop gain = -1 when the output driving a  $1k\Omega$  load at  $20V_{pp}$ . The LME49990 behaves very stable in shape step response and have a minimal ringing in both small and large signal step response (See Typical Performance Characteristic). The slew rate typical value reach as high as  $\pm 18V/\mu s$  was measured when the output reach -20V refer to the start point when input voltage equals to zero.

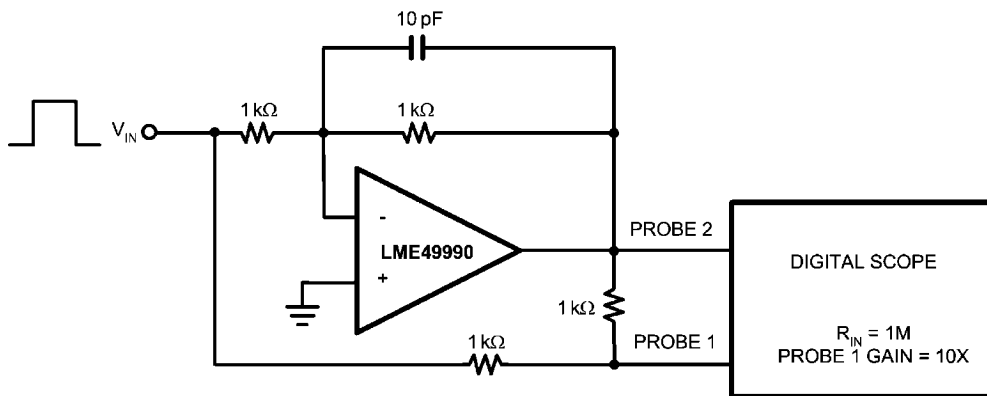

FIGURE 6: Settling Time Test Circuit

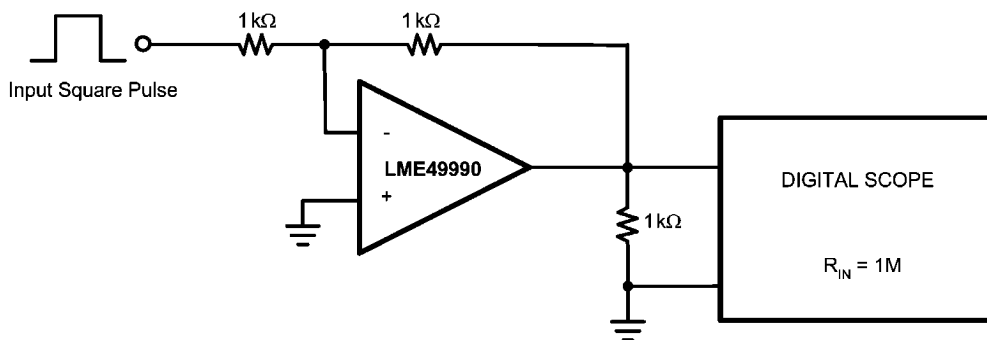

FIGURE 7: Slew Rate Test Circuit

### DISTORTION MEASUREMENTS

The vanishingly low residual distortion produced by LME49990 is below the capabilities of all commercially available equipment. This makes distortion measurements just slightly more difficult than simply connecting a distortion meter to the amplifier's inputs and outputs. The solution, however, is quite simple: an additional resistor. Adding this resistor extends the resolution of the distortion measurement equipment.

The LME49990's low residual distortion is an input referred internal error. As shown in Figure 8, adding the  $10\Omega$  resistor connected between the amplifier's inverting and non-inverting inputs changes the amplifier's noise gain. The result is that

the error signal (distortion) is amplified by a factor of 101. Although the amplifier's closed-loop gain is unaltered, the feedback available to correct distortion errors is reduced by 101, which means that measurement resolution increases by 101. To ensure minimum effects on distortion measurements, keep the value of  $R_1$  low as shown in Figure 8.

This technique is verified by duplicating the measurements with high closed loop gain and/or making the measurements at high frequencies. Doing so produces distortion components that are within the measurement equipment's capabilities. This datasheet's THD+N and IMD values were generated using the above described circuit connected to an Audio Precision System Two Cascade.

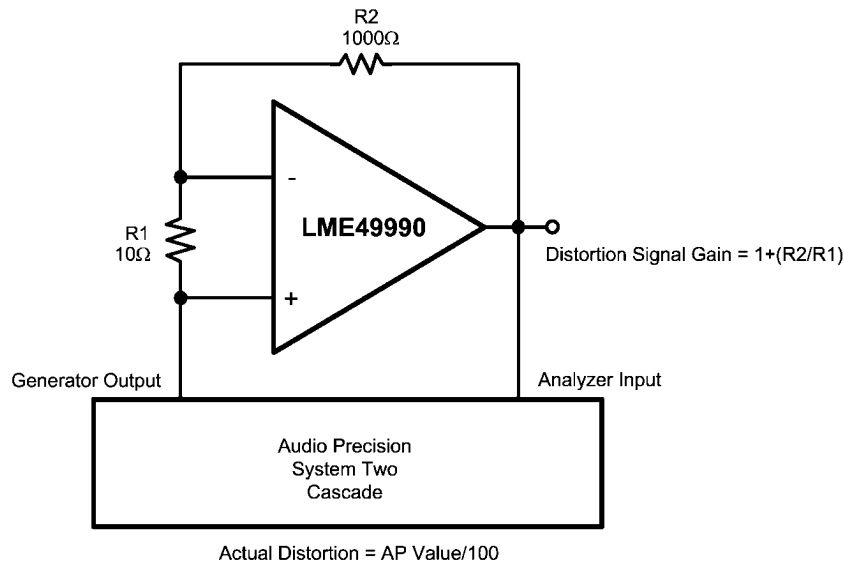

**FIGURE 8: THD+N and IMD Distortion Test Circuit**

30059707

## Revision History

Rev	Date	Description
1.0	12/16/09	Initial released.
1.01	01/08/10	Input text edits.

**Physical Dimensions** inches (millimeters) unless otherwise noted

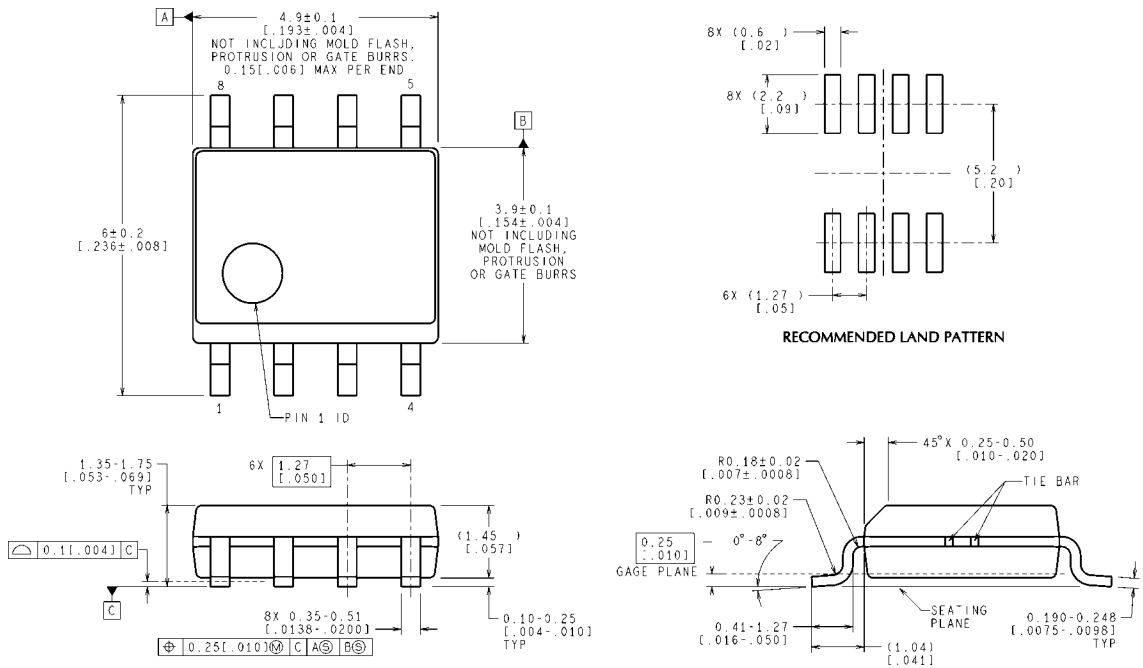

CONTROLLING DIMENSION IS MILLIMETER  
VALUES IN [ ] ARE INCHES  
DIMENSIONS IN ( ) FOR REFERENCE ONLY

M08A (Rev M)

**Dual-In-Line Package**  
**Order Number LME49990MA**  
**NS Package Number M08A**

## Notes

LME49990

## Notes

For more National Semiconductor product information and proven design tools, visit the following Web sites at:  
[www.national.com](http://www.national.com)

Products		Design Support	
Amplifiers	<a href="http://www.national.com/amplifiers">www.national.com/amplifiers</a>	WEBENCH® Tools	<a href="http://www.national.com/webench">www.national.com/webench</a>
Audio	<a href="http://www.national.com/audio">www.national.com/audio</a>	App Notes	<a href="http://www.national.com/appnotes">www.national.com/appnotes</a>
Clock and Timing	<a href="http://www.national.com/timing">www.national.com/timing</a>	Reference Designs	<a href="http://www.national.com/refdesigns">www.national.com/refdesigns</a>
Data Converters	<a href="http://www.national.com/adc">www.national.com/adc</a>	Samples	<a href="http://www.national.com/samples">www.national.com/samples</a>
Interface	<a href="http://www.national.com/interface">www.national.com/interface</a>	Eval Boards	<a href="http://www.national.com/evalboards">www.national.com/evalboards</a>
LVDS	<a href="http://www.national.com/lvds">www.national.com/lvds</a>	Packaging	<a href="http://www.national.com/packaging">www.national.com/packaging</a>
Power Management	<a href="http://www.national.com/power">www.national.com/power</a>	Green Compliance	<a href="http://www.national.com/quality/green">www.national.com/quality/green</a>
Switching Regulators	<a href="http://www.national.com/switchers">www.national.com/switchers</a>	Distributors	<a href="http://www.national.com/contacts">www.national.com/contacts</a>
LDOs	<a href="http://www.national.com/ldo">www.national.com/ldo</a>	Quality and Reliability	<a href="http://www.national.com/quality">www.national.com/quality</a>
LED Lighting	<a href="http://www.national.com/led">www.national.com/led</a>	Feedback/Support	<a href="http://www.national.com/feedback">www.national.com/feedback</a>
Voltage References	<a href="http://www.national.com/vref">www.national.com/vref</a>	Design Made Easy	<a href="http://www.national.com/easy">www.national.com/easy</a>
PowerWise® Solutions	<a href="http://www.national.com/powerwise">www.national.com/powerwise</a>	Applications & Markets	<a href="http://www.national.com/solutions">www.national.com/solutions</a>
Serial Digital Interface (SDI)	<a href="http://www.national.com/sdi">www.national.com/sdi</a>	Mil/Aero	<a href="http://www.national.com/milaero">www.national.com/milaero</a>
Temperature Sensors	<a href="http://www.national.com/tempensors">www.national.com/tempensors</a>	SolarMagic™	<a href="http://www.national.com/solarmagic">www.national.com/solarmagic</a>
PLL/VCO	<a href="http://www.national.com/wireless">www.national.com/wireless</a>	PowerWise® Design University	<a href="http://www.national.com/training">www.national.com/training</a>

THE CONTENTS OF THIS DOCUMENT ARE PROVIDED IN CONNECTION WITH NATIONAL SEMICONDUCTOR CORPORATION ("NATIONAL") PRODUCTS. NATIONAL MAKES NO REPRESENTATIONS OR WARRANTIES WITH RESPECT TO THE ACCURACY OR COMPLETENESS OF THE CONTENTS OF THIS PUBLICATION AND RESERVES THE RIGHT TO MAKE CHANGES TO SPECIFICATIONS AND PRODUCT DESCRIPTIONS AT ANY TIME WITHOUT NOTICE. NO LICENSE, WHETHER EXPRESS, IMPLIED, ARISING BY ESTOPPEL OR OTHERWISE, TO ANY INTELLECTUAL PROPERTY RIGHTS IS GRANTED BY THIS DOCUMENT.

TESTING AND OTHER QUALITY CONTROLS ARE USED TO THE EXTENT NATIONAL DEEMS NECESSARY TO SUPPORT NATIONAL'S PRODUCT WARRANTY. EXCEPT WHERE MANDATED BY GOVERNMENT REQUIREMENTS, TESTING OF ALL PARAMETERS OF EACH PRODUCT IS NOT NECESSARILY PERFORMED. NATIONAL ASSUMES NO LIABILITY FOR APPLICATIONS ASSISTANCE OR BUYER PRODUCT DESIGN. BUYERS ARE RESPONSIBLE FOR THEIR PRODUCTS AND APPLICATIONS USING NATIONAL COMPONENTS. PRIOR TO USING OR DISTRIBUTING ANY PRODUCTS THAT INCLUDE NATIONAL COMPONENTS, BUYERS SHOULD PROVIDE ADEQUATE DESIGN, TESTING AND OPERATING SAFEGUARDS.

EXCEPT AS PROVIDED IN NATIONAL'S TERMS AND CONDITIONS OF SALE FOR SUCH PRODUCTS, NATIONAL ASSUMES NO LIABILITY WHATSOEVER, AND NATIONAL DISCLAIMS ANY EXPRESS OR IMPLIED WARRANTY RELATING TO THE SALE AND/OR USE OF NATIONAL PRODUCTS INCLUDING LIABILITY OR WARRANTIES RELATING TO FITNESS FOR A PARTICULAR PURPOSE, MERCHANTABILITY, OR INFRINGEMENT OF ANY PATENT, COPYRIGHT OR OTHER INTELLECTUAL PROPERTY RIGHT.

#### LIFE SUPPORT POLICY

**NATIONAL'S PRODUCTS ARE NOT AUTHORIZED FOR USE AS CRITICAL COMPONENTS IN LIFE SUPPORT DEVICES OR SYSTEMS WITHOUT THE EXPRESS PRIOR WRITTEN APPROVAL OF THE CHIEF EXECUTIVE OFFICER AND GENERAL COUNSEL OF NATIONAL SEMICONDUCTOR CORPORATION.** As used herein:

Life support devices or systems are devices which (a) are intended for surgical implant into the body, or (b) support or sustain life and whose failure to perform when properly used in accordance with instructions for use provided in the labeling can be reasonably expected to result in a significant injury to the user. A critical component is any component in a life support device or system whose failure to perform can be reasonably expected to cause the failure of the life support device or system or to affect its safety or effectiveness.

National Semiconductor and the National Semiconductor logo are registered trademarks of National Semiconductor Corporation. All other brand or product names may be trademarks or registered trademarks of their respective holders.

Copyright© 2010 National Semiconductor Corporation

For the most current product information visit us at [www.national.com](http://www.national.com)



**National Semiconductor Americas Technical Support Center**  
 Email: [support@nsc.com](mailto:support@nsc.com)  
 Tel: 1-800-272-9959

**National Semiconductor Europe Technical Support Center**  
 Email: [europe.support@nsc.com](mailto:europe.support@nsc.com)

**National Semiconductor Asia Pacific Technical Support Center**  
 Email: [ap.support@nsc.com](mailto:ap.support@nsc.com)

**National Semiconductor Japan Technical Support Center**  
 Email: [jpn.feedback@nsc.com](mailto:jpn.feedback@nsc.com)